

Pilot operated pressure reducing relief valves are used to maintain pressure constant irrespective of flow direction. The valve can be subplate mounted in any position in hydraulic systems. Sealing of interfaces is made by means of o-rings included with the valve.

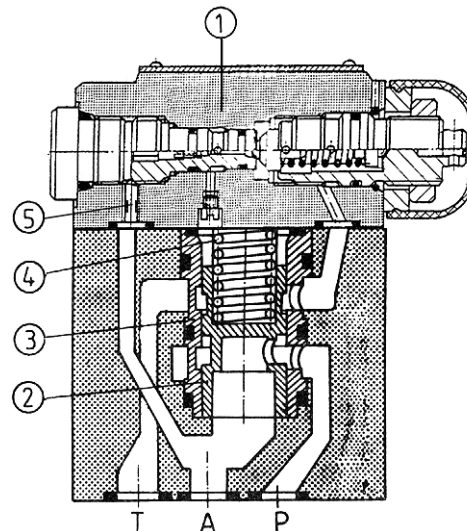

DESCRIPTION OF OPERATION

Pressure is set at the pilot valve 1. If the pilot valve is open, pilot fluid flows through it. This flow is branched out the main flow reduced by the hydraulic cascade 5 and affects the main valve spool 2 which mates with the cylindrical surface of the sleeve 3. The spool movement is limited by the spring 4.



Version W

If pressure in line A exceeds the set value, the pilot valve opens allowing fluid to drain to a tank via line Y (external drainage) or via line T (internal drainage). Opening the pilot valve disturbs the state of equilibrium at the main spool and causes a new dumping gap to establish so that pressure behind it was flow rate independent.

If in line A is large pressure increase that causes the connection P to A to close and the connection A to T to open, the valve operates as a pressure relief valve. It protects the system against the excessive pressure increase and at the same time it stabilizes the pressure at a requested level irrespective of flow direction.

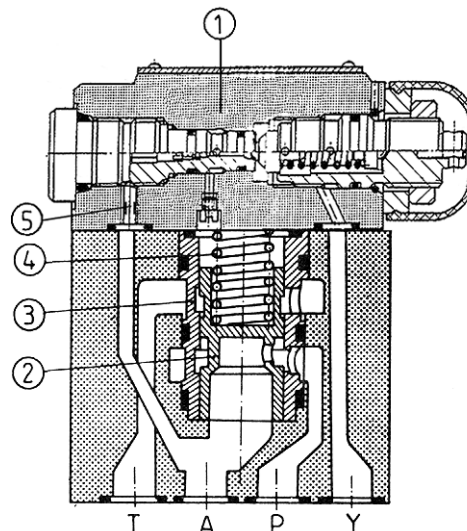

Version Y

TECHNICAL DATA

Hydraulic fluid	Mineral oil or phosphate ester
Nominal fluid viscosity	37 mm ² /s at the temperature of 328 K
Viscosity range	2.8 to 380 mm ² /s
Optimum working temperature(fluid in a tank)	313 - 328 K
Fluid temperature range	243 - 343 K
Required fluid filtration	16 μm
Recommended fluid filtration	10 μm
Maximum operating pressure	31.5 MPa
Average pilot fluid flow rate	0.55 dm ³ /min
Weight	4.3 kg

OVERALL DIMENSIONS

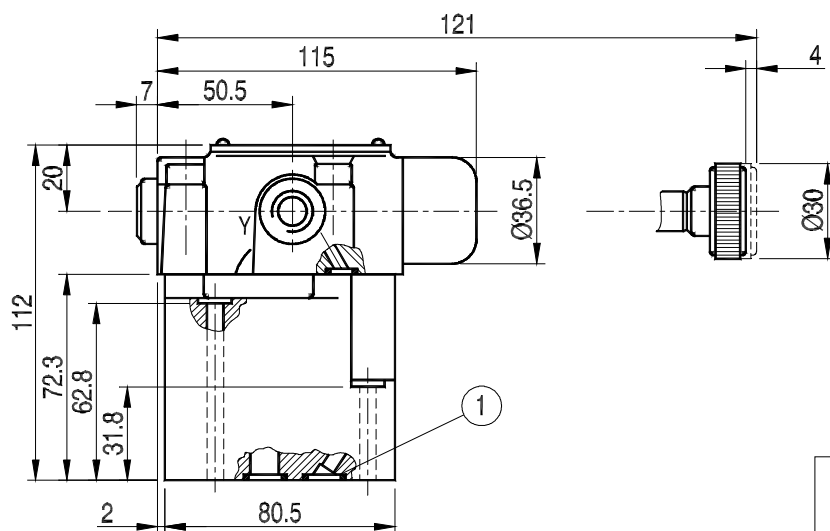
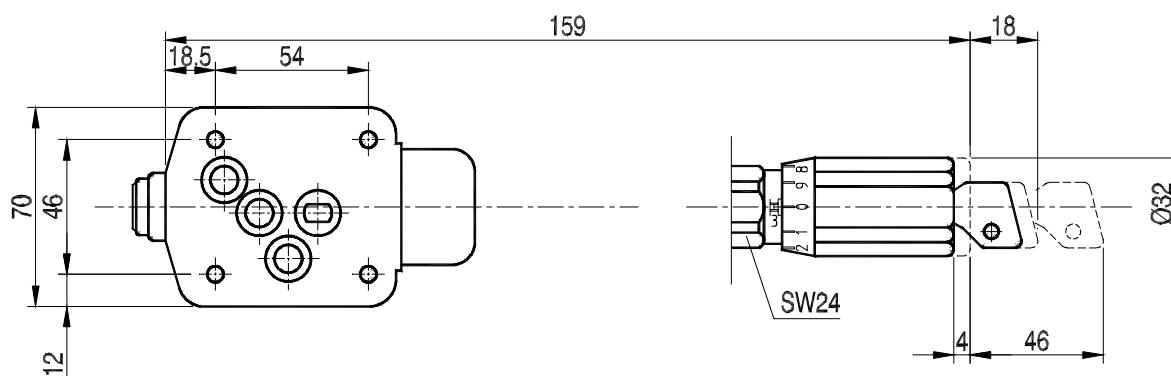

item 1 - o-ring 12 × 2 - 4 pcs for varsoin Y
 - 3 pcs for version W

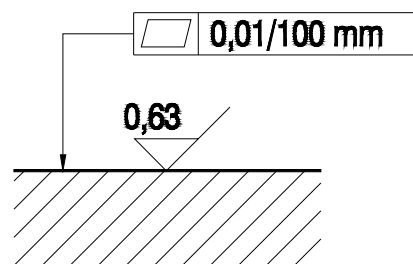

Admissible surface roughness and flatness deviation for a subplate face.

PERFORMANCE CURVES, measured at $v = 41 \text{ mm}^2/\text{s}$ and $T = 323 \text{ K}$

Flow curve

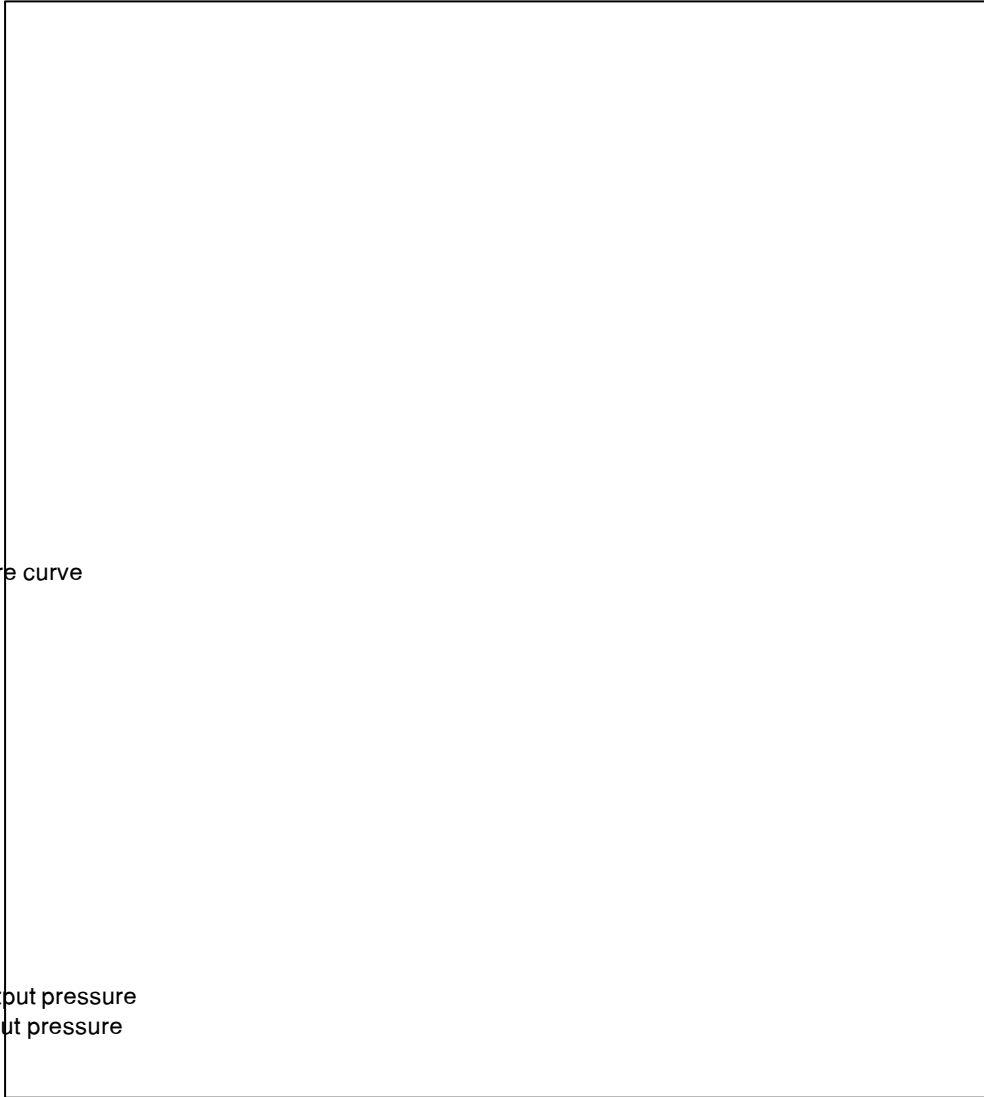

P_A - output pressure
 P_p - input pressure

SCHEMES :

Hydraulic scheme

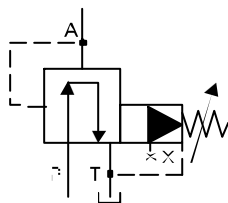

for version W

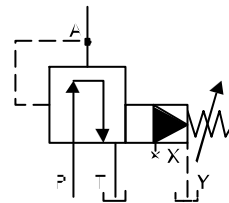

for version Y

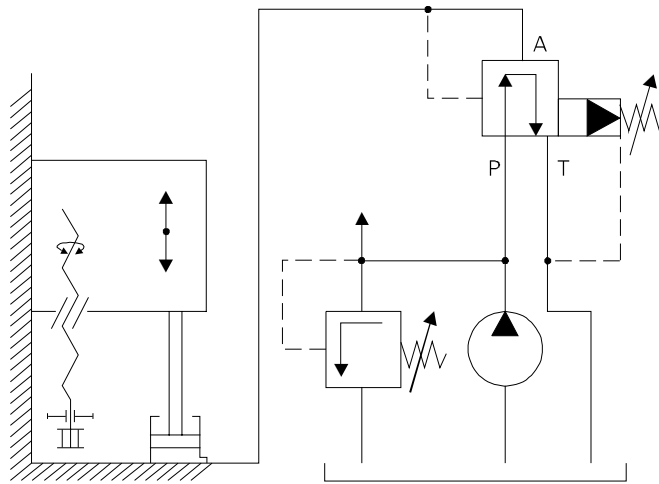

Example of application of pressure reducing relief valve

HOW TO ORDER

Orders coded in the way showed below should be forwarded to the manufacturer.

UZCP 10 - / / / / *

Series number

22 = 22
 (20 - 29) - installation and connection
 dimensions remain unchanged

Further requirements in clear text
 (to be agreed upon with the manu-
 facturer)

Set pressure range

up to 10 MPa = 100
 up to 31.5 MPa = 315

Sealing

Fluids on mineral oil base = with no code
 Fluids on phosphate-ester base = V

Pilot fluid supply and drain

Internal supply, internal drain = W
 Internal supply, external drain = Y

Adjustment method

Hand knob = 1
 Set screw = 2
 Lockable hand knob = 3

Coding example : UZCP 10 - 22/315 W2

Connection dimensions for subplate

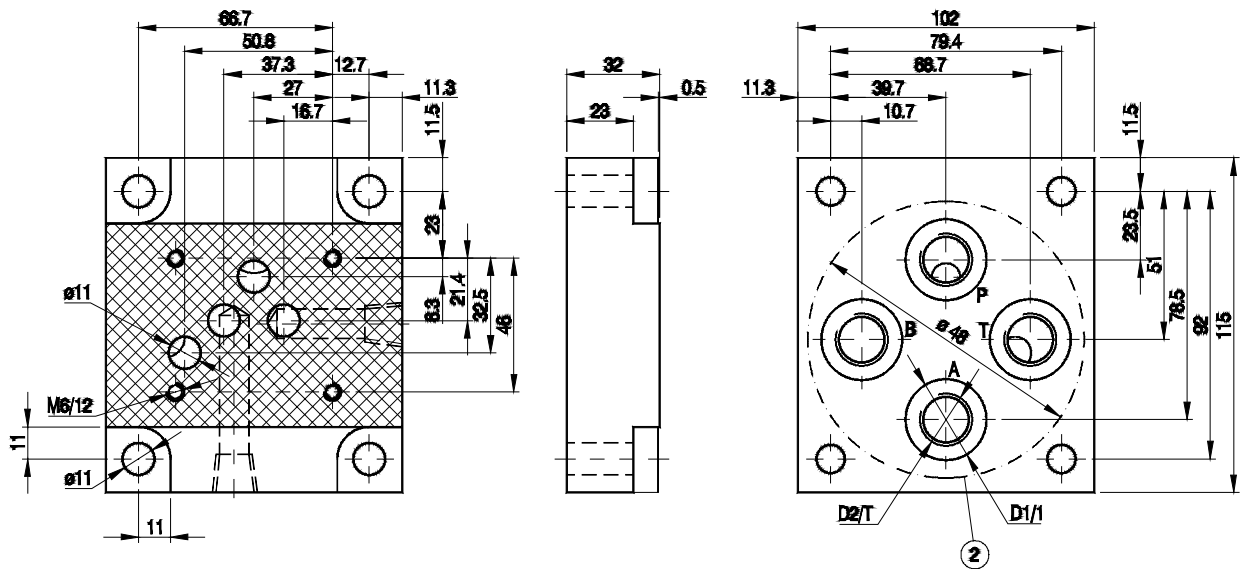

- item 1 - connecting face
- item 2 - recess in subplate face

Weight ~ 2.3 kg

Type	D1	D2	T	Type	D1	D2	T
G 89/01	25	G 1/4	12	G 89/02	24	M14 x 1.5	15
G 66/01	28	G 3/8	12	G 66/02	28	M16 x 1.5	17
G 67/01	34	G 1/2	14	G 67/02	36	M22 x 1.5	17

Fixing the valve to the subplate by means of 2 bolts M6 x 70 - 10.9 PN-74/M-82302 (DIN 912) and 2 bolts M6 x 40 - 10.9 PN - 74/M-82302 (DIN 912). Tightening torque - 15 Nm.

Bolts and subplates have to be ordered separately.

PONAR WADOWICE S.A.
ul. Wojska Polskiego 29
34-100 Wadowice
tel. 033/ 823 39 43, 823 30 41
fax 033/ 873 48 80
e-mail: ponar@ponar-wadowice.pl

