

Double throttle/check valves serve to control the main flow or pilot flow rate in one direction and give free flow in the opposite direction.

Valve type Z2FS6 is a double throttle/check adopted for vertical stack mounting ( sandwich plate design ).

Two symmetrically fitted in one block throttle/check valves limit the flow rate in one direction by means of an adjustable throttle pin and allow free flow through the check valve in the opposite direction.

The valve Z2FS6 is generally mounted between a subplate and direct operated directional valve of corresponding size and serves here to limit the main flow rate ( to influence the speed of a user ). With pilot operated valve, the double throttle/check valve may be used as pilot choke adjustment ( pilot flow limiter ). In this case it will be fitted between pilot and main valve.



## DESCRIPTION OF OPERATION

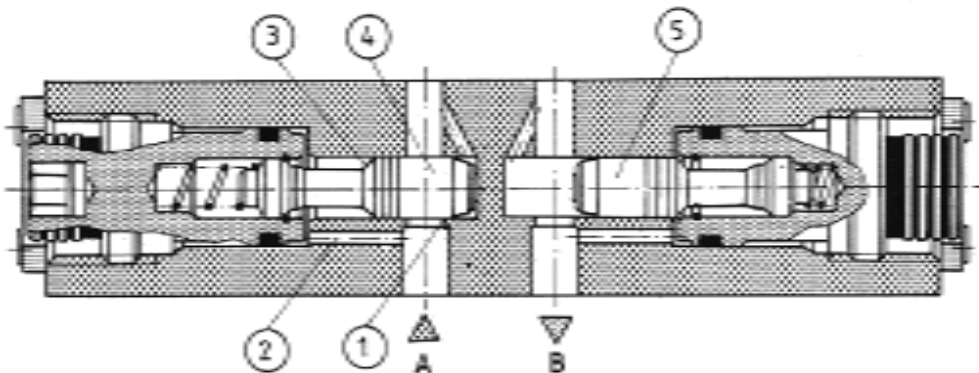

Hydraulic fluid in line A flows to a user through the throttle position 1. At the same time, the fluid being under operating pressure reaches the spring loaded side 3 of the spool 4 via the line 2. The spool 4 is thus hold in the throttle position by both spring and pressure force.

Fluid returning from the user shifts the spool 5 to the right and permits the fluid to flow freely through the valve cartridge now acting as a check valve.

According to the mounting position of the valve, throttle effect can be achieved in the supply or drain.

## TECHNICAL DATA

Hydraulic fluid	Mineral oil or phosphate ester
Nominal fluid viscosity	37 mm <sup>2</sup> /s at the temperature of 328 K
Viscosity range	2.8 to 380 mm <sup>2</sup> /s
Optimum working temperature (fluid in a tank )	313 - 328 K
Fluid temperature range	243 - 343 K
Filtration	up to 16 μm
Maximum operating pressure	31.5 MPa
Cracking pressure	0.05 MPa

## OVERALL DIMENSIONS

Weight - 0.8 kg

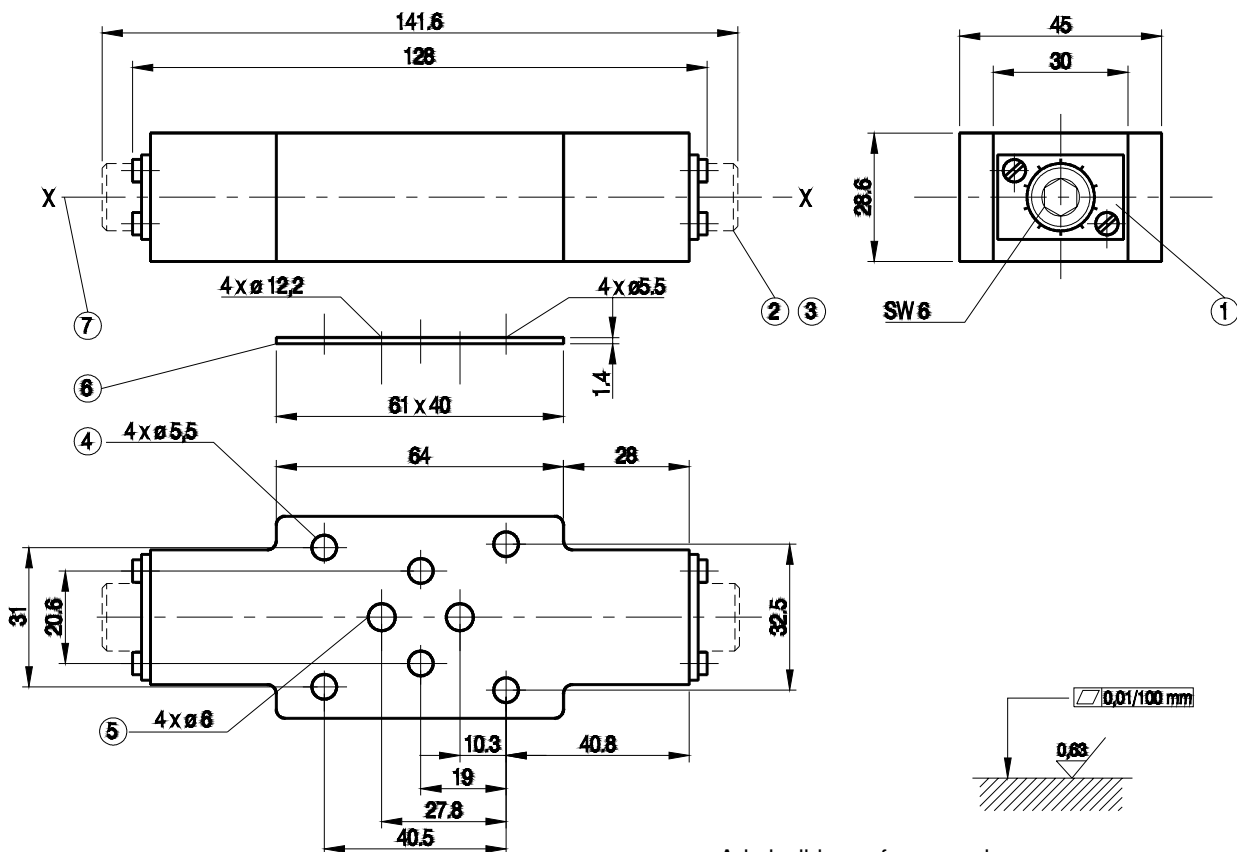

Admissible surface roughness and flatness deviation for a subplate face.

- 1 - Name plate with scale
- 2 - Set screw to change flow section
- 3 - Rotation to the left - decreasing switching time  
Rotation to the right - increasing switching time
- 4 - Four holes for valve mounting
- 5 - O-rings - 9.2 × 1.8 - 4 pcs
- 6 - Plate for o-rings fixing
- 7 - Conversion from throttling in the supply for throttling in the drain can be done by rotating the valve round the axis X-X.

**PERFORMANCE CURVES**, measured at  $\nu = 41 \text{ mm}^2/\text{s}$  and  $T = 323 \text{ K}$

Pressure drop  $\Delta p$  in relation to flow rate  $Q$  over check/throttle valve

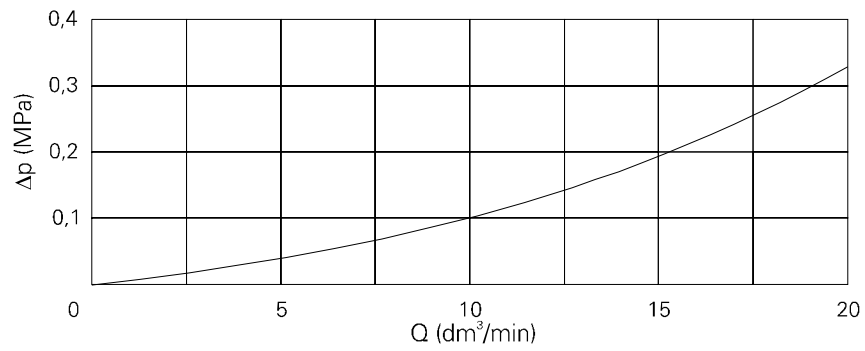

Pressure drop  $\Delta p$  in relation to flow rate  $Q$  with constant throttling

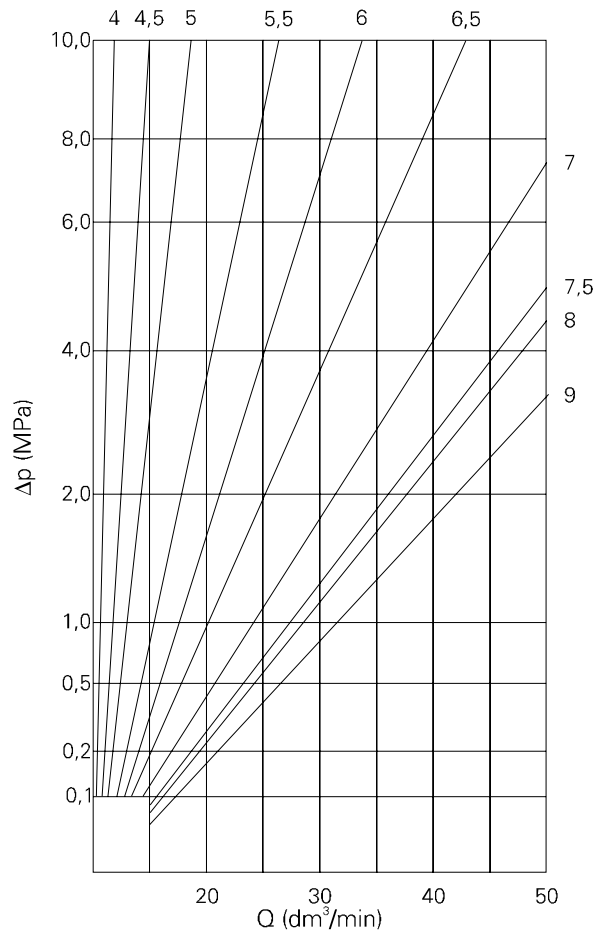

## SCHEMES

Graphical symbols and the examples of application of the valve with throttling in the supply and drain

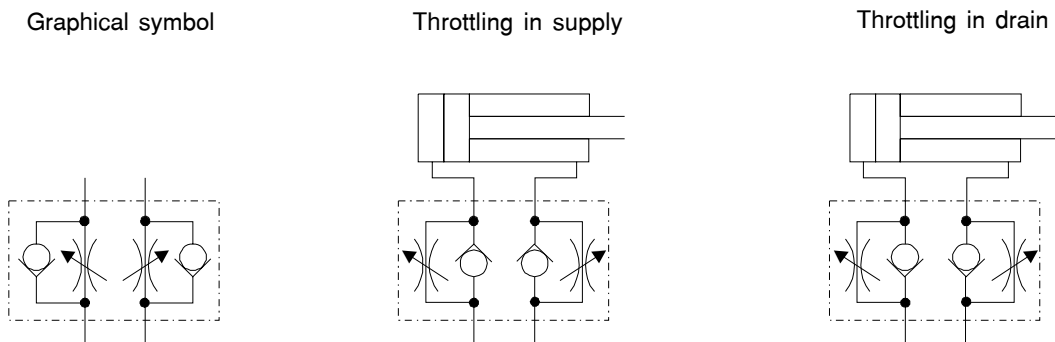

## HOW TO ORDER

Orders coded in the way showed below should be forwarded to the manufacturer.

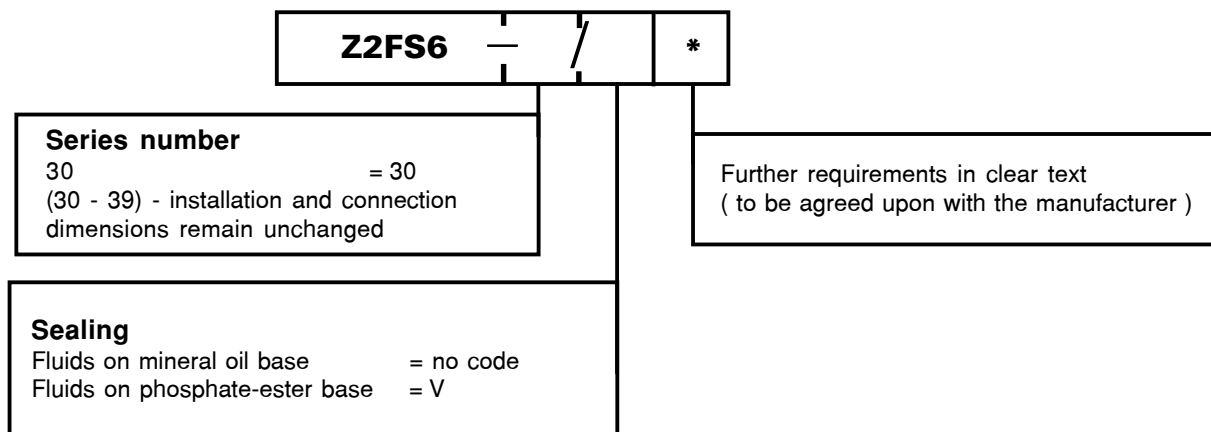

Coding example : Z2FS6-30/V

PONAR WADOWICE S.A.  
 ul. Wojska Polskiego 29  
 34-100 Wadowice  
 tel. 033/ 823 39 43, 823 30 41  
 fax 033/ 873 48 80  
 e-mail: ponar@ponar-wadowice.pl

