

Directional control valves afford possibilities for controlling start, stop and direction of flow of a pressure fluid and thus accordingly start, stop and direction of movement of a user (cylinder or hydraulic motor).
The directional valves may be mounted in hydraulic systems in any desired position together with a subplate.
Sealing of mating faces is made by using O-rings which are included with the valve.

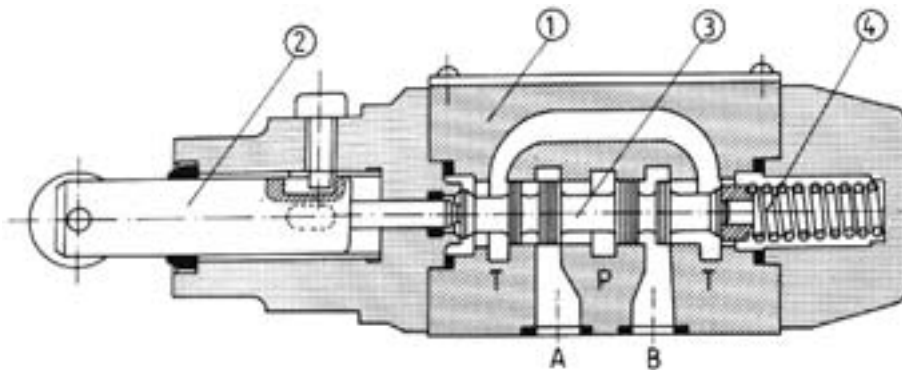

DESCRIPTION OF OPERATION



The directional valve is switched by changing the position of the spool 3 which moving along its axis separates or connects ports A, B, P or T in the housing 1. The spool is shifted

by means of the lifter with the roller 2. The spring 4 causes the lifter to move back.

The directional valve is available as three-position or two-position valve.

TECHNICAL DATA

Hydraulic fluid	Mineral oil, phosphate ester	
Required filtration	up to 16 μ m	
Recommended filtration	up to 10 μ m	
Nominal fluid viscosity	37 mm ² at temp. of 328 K	
Viscosity range	2.8 to 380 mm ² /s	
Optimum working temperature (fluid in a tank)	313 - 328 K	
Fluid temperature range	243 - 343 K	
Maximum operating pressure	Port P, A, B	Port T
	31.5 MPa	6 MPa
Weight	1.4 kg	
Operating force on roller	100 - 200 N	

OVERALL DIMENSIONS

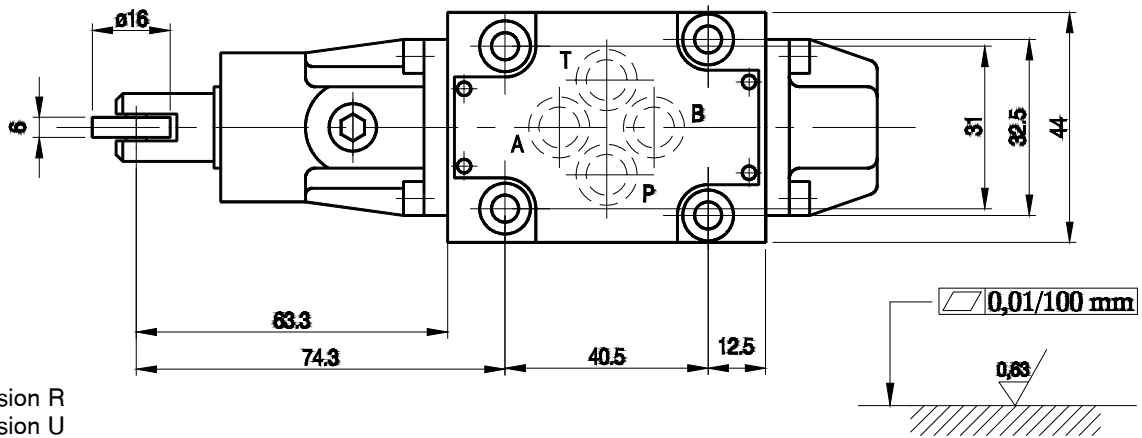
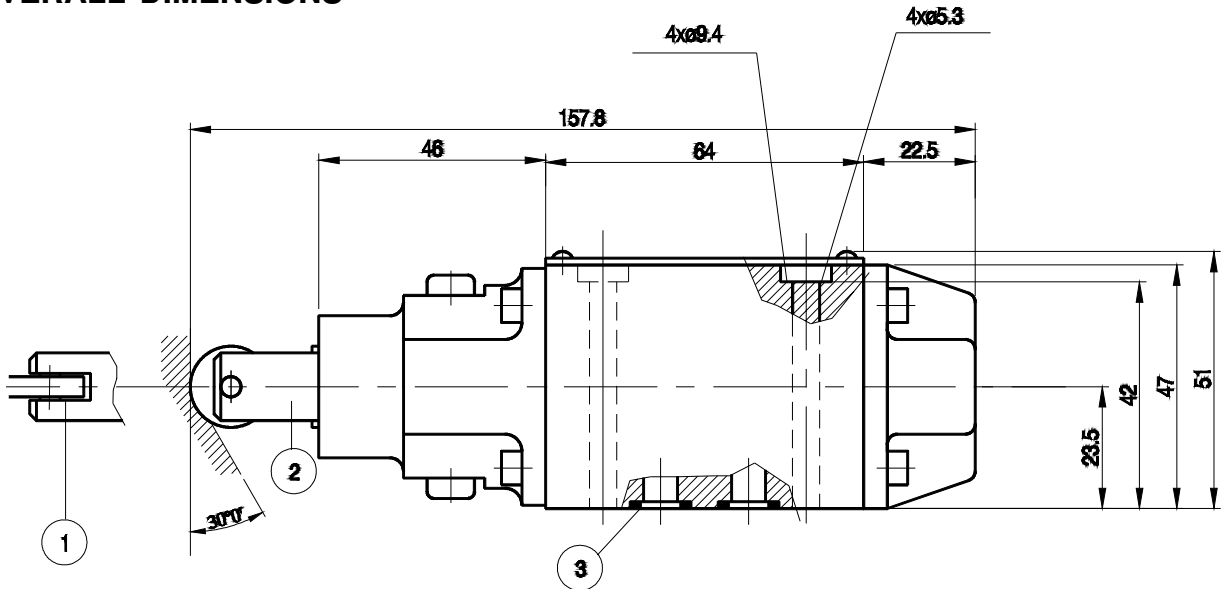

- item 1 - version R
- item 2 - version U
- item 3 - O-ring 9.2 × 1.8 - 4 pieces

Permissible surface roughness and flatness deviation for a subplate face.

Lifter position

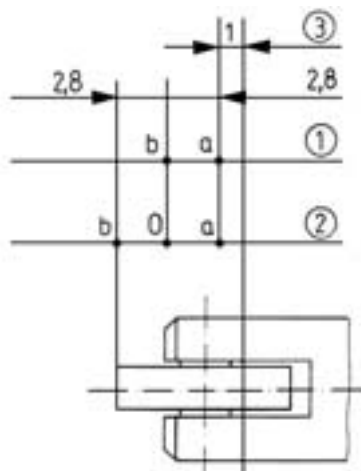

- item 1 - for spool types A, C, D
- item 2 - for spool types E to W
- item 3 - coating (does not belong to working range of valve)

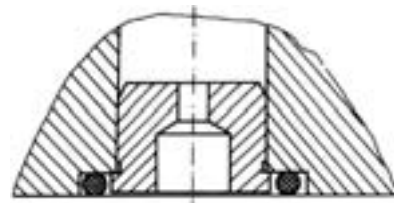

Mounting method for throttle insert in port P

PERFORMANCE CURVES : measured at $v = 41 \text{ mm}^2/\text{s}$ and $T = 323 \text{ K}$

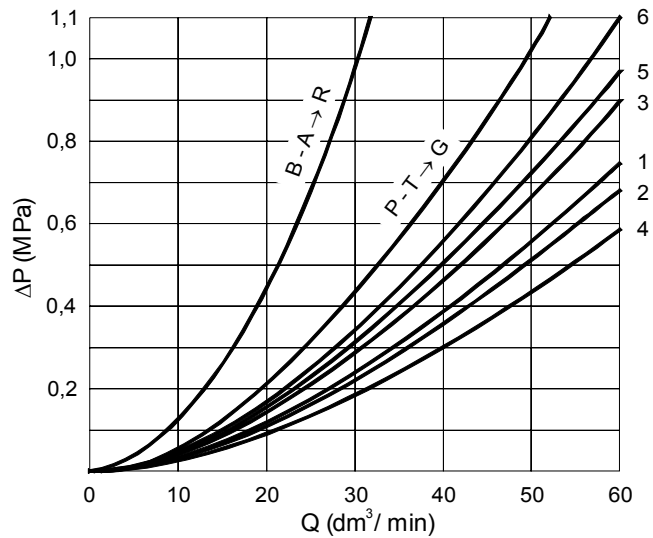

	A	B	C	D	E	F	G	H	J	L	M	P	Q	R	T	U	V	W	Y
P - A	3	3	1	5	3	2	5	2	1	1	2	2	1	5	5	3	1	1	5
P - B	3	3	1	5	3	3	3	4	1	1	4	3	1	5	3	1	2	1	5
A - T	-	-	3	3	1	3	6	2	2	2	3	3	2	4	6	3	1	2	3
B - T	-	-	1	3	1	5	6	2	1	2	3	5	1		6	3	1	2	3

Flow curves for various spool types

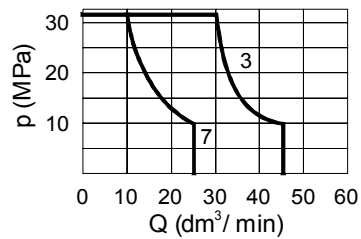
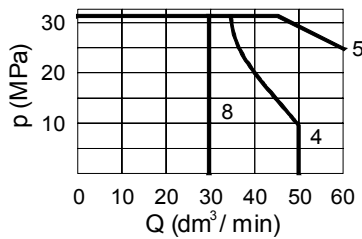

Note:

The flow limits refer to typical application of 4-way directional control valve i.e. with using two lines e.g. P to A and B to T at the same time. In case of using 4-way directional control valve with one flow line e.g. P to A (B plugged) or A to T (B plugged) actual flow limits are considerably lower.

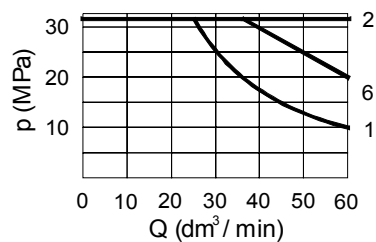

	1	2	3	4	5	6	7	8
A		C, D, E, E1, H, M, Q, U, W	F, P	G	J, L	R	T	V

Flow curves for directional valve and various spool types

SCHEMES

Hydraulic scheme for directional control valve

- item 1 - two - position directional valve
- item 3 - three - position directional valve

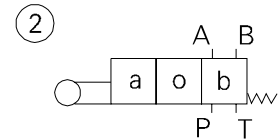
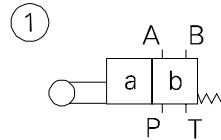

Spool schemes

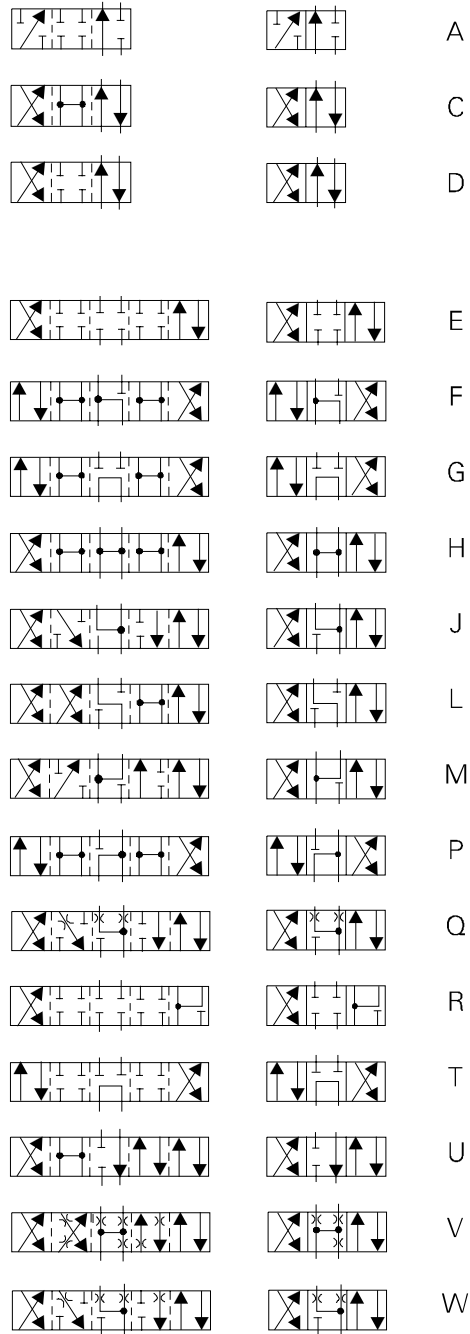

Note : Scheme E has version E1 with overlap positions as for spool P.
 Spool type W makes section open in neutral position in approx. 3 % of nominal section.
 Spool type W makes section open in neutral position in approx. 6 % of nominal section.

HOW TO ORDER

Orders coded in the way showed below should be forwarded to the manufacturer.

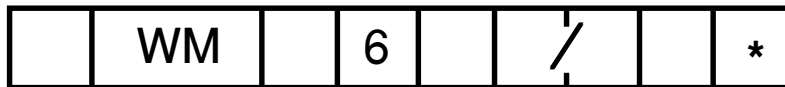

Number of service ports
 3 = 3
 4 = 4

Position of lifter with roller
 operating plane of lifter with roller parallel to mating face = R
 operating plane of lifter with roller perpendicular to mating face = U

Control spool type
 See spool schemes on page 4

Series number
 50 = 50
 (50 - 59) - installation and connection dimensions unchanged

Additional requirements in clear text (to be agreed with the manufacturer)

Sealing
 For fluids on mineral oil base = with no designation
 For fluids on phosphate ester base = V

Throttle insert
 Without throttle insert = with no design.
 Throttle insert \varnothing 0.8 = B08
 Throttle insert \varnothing 1.0 = B10
 Throttle insert \varnothing 1.2 = B12

Coding example : 4WMR6E1-50/B08

MOUNTING DIMENSIONS FOR SUBPLATE

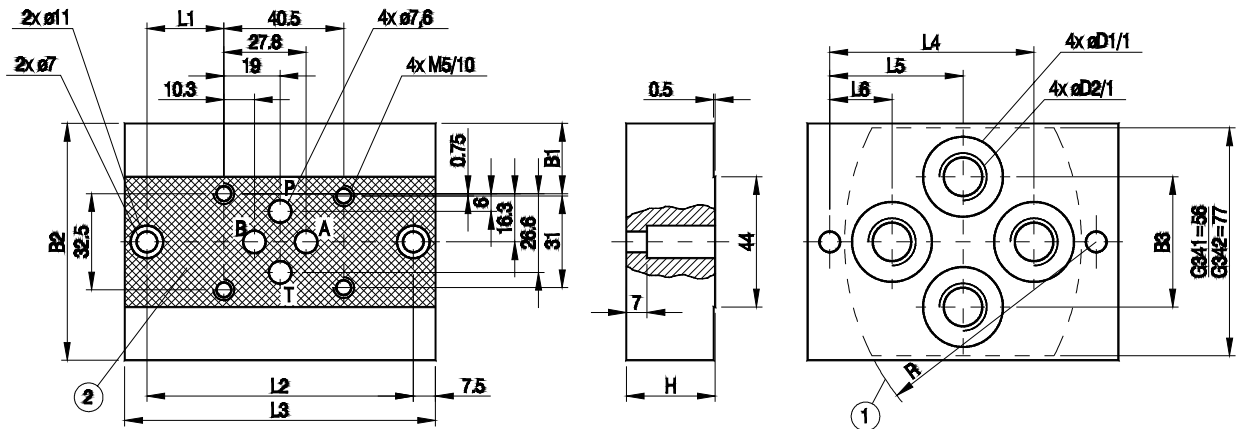

- 1 - Mounting face
- 2 - Recess in subplate face

Subplate weight - approx. 0.8 kg

Type	B1	B2	B3	L1	L2	L3	L4	L5	L6	H	D1	D2	R	T
G341/01	12.7	58	34	21	80	95	55	40	25	25	22	G1/4	70	13
G342/01	23.7	80	44	26	90	105	69	45	21	30	28	G3/8	85	13
G341/02	12.7	58	34	21	80	95	55	40	25	25	22	M14×1.5	70	15
G342/02	23.7	80	44	26	90	105	69	45	21	30	27	M16×1.5	85	16

Bolts mounting valve to subplate	Md
4 × M5 × 50 -10.9 per PN-74/M-82302 (DIN 912)	9 Nm

Note : Subplate and mounting bolts must be ordered separately

PONAR WADOWICE S.A.
 ul. Wojska Polskiego 29
 34-100 Wadowice
 tel. 033/ 823 39 43, 823 30 41
 fax 033/ 873 48 80
 e-mail: ponar@ponar-wadowice.pl

