

Directional control valves afford possibilities for controlling start, stop and direction of flow of a pressure fluid and thus accordingly start, stop and direction of movement of a user ( cylinder or hydraulic motor ).

The directional valves may be mounted in hydraulic systems in any desired position together with a subplate.

Sealing of mating faces is made by using O-rings which are included with the valve.



**DESCRIPTION OF OPERATION**

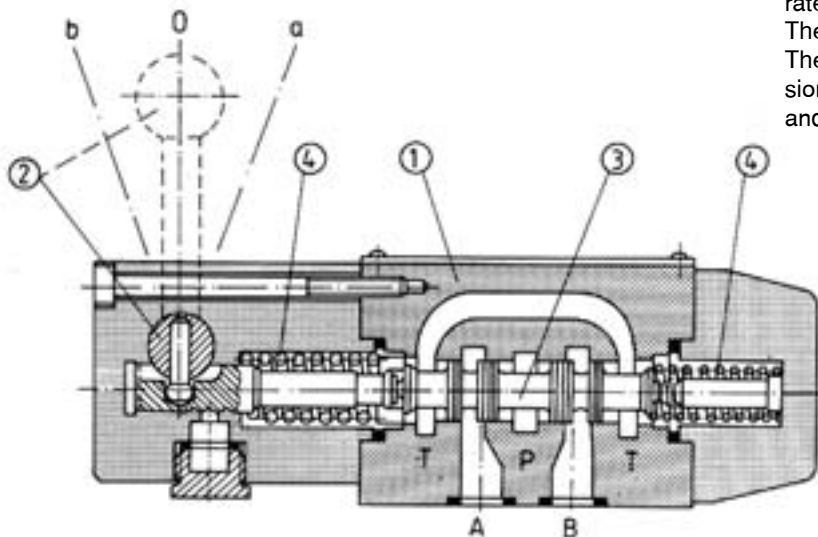
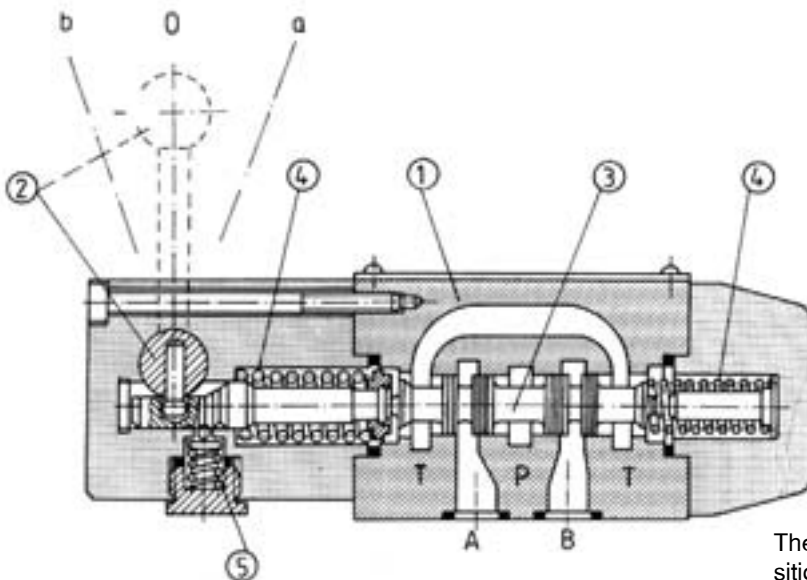

The directional valve is switched by changing the position of the spool 3 which moving along its axis separates or connects ports A, B, P or T in the housing 1. The spool is shifted by means of the hand lever 2. The directional valve is available in the following versions: three-position with return spring 4 or detent 5 and two-position with return spring 4 or detent 5.

## TECHNAICAL DATA

Hydraulic fluid		Mineral oil, phosphate ester	
Required filtration		up to 16 $\mu\text{m}$	
Recommended filtration		up to 10 $\mu\text{m}$	
Nominal fluid viscosity		37 $\text{mm}^2$ at temp. of 328 K	
Viscosity range		2.8 to 380 $\text{mm}^2/\text{s}$	
Optimum working temperature ( fluid in a tank )		313 - 328 K	
Fluid temperature range		243 - 343 K	
Maximum operating pressure		Port P, A, B	Port T
		31.5 MPa	16 MPa
Operating force on hand lever	without pressure in port T	approx. 20 N	
	pressure in port T 15 MPa	approx. 30 N	
Weight		1.4 kg	

## OVERALL DIMENSIONS

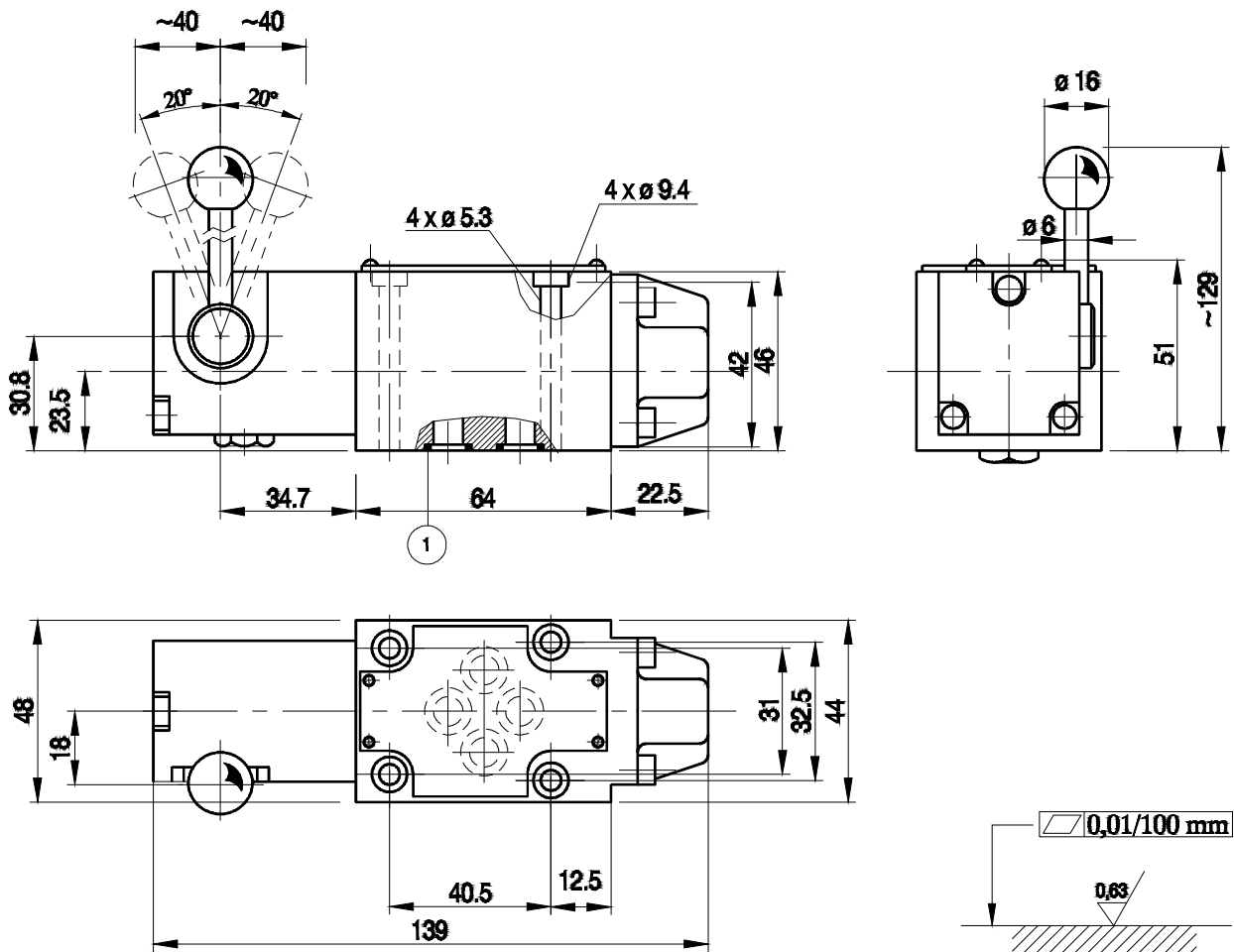

item 1 - O - ring 9.2 x 1.8 - 4 pieces

Permissible surface roughness and flatness deviation for a subplate face.

Hand lever position

- item 1 - for spool types A, C, D
- item 2 - for spool types B, Y
- item 3 - for spool types EA to WA
- item 4 - for spool types EB to WB
- item 5 - for spool types E to W

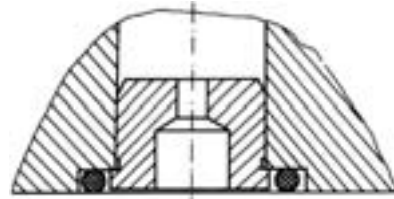

Mounting method for throttle insert in port P

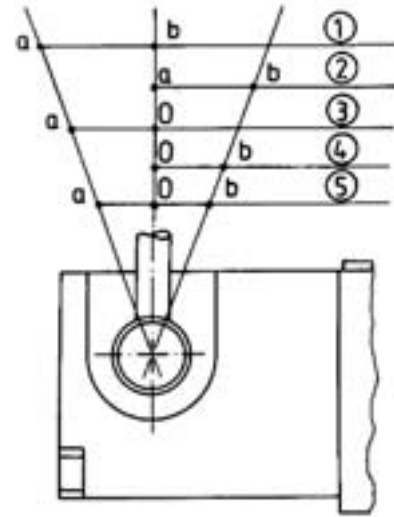

**PERFORMANCE CURVES** : measured at  $\nu = 41 \text{ mm}^2/\text{s}$  and  $T = 323 \text{ K}$

Flow curves for various spool types

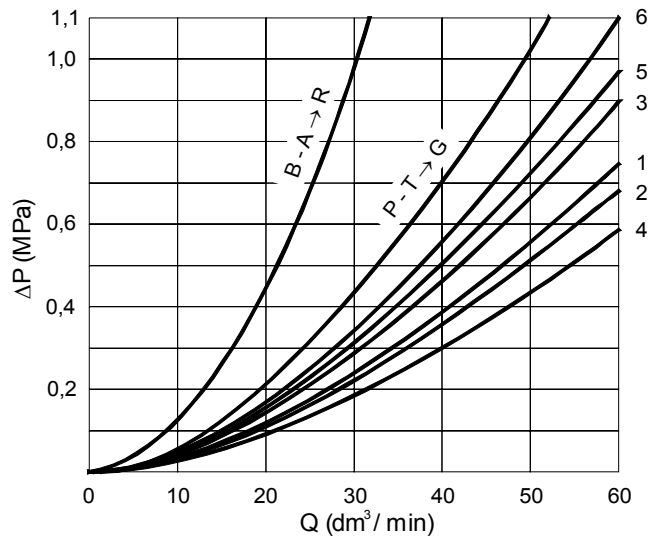

	A	B	C	D	E	F	G	H	J	L	M	P	Q	R	T	U	V	W	Y
P - A	3	3	1	5	3	2	5	2	1	1	2	2	1	5	5	3	1	1	5
P - B	3	3	1	5	3	3	3	4	1	1	4	3	1	5	3	1	2	1	5
A - T	-	-	3	3	1	3	6	2	2	2	3	3	2	4	6	3	1	2	3
B - T	-	-	1	3	1	5	6	2	1	2	3	5	1		6	3	1	2	3

Flow curves for valves with return springs and various spool types

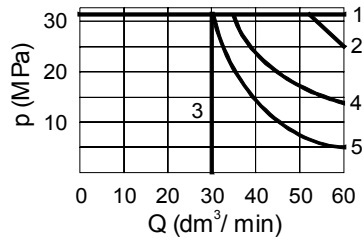

1	2	3	4	5
E1, M, E, J, L, Q, U, W, C, D, Y, G, H, R	A, B	V	F, P	T

Flow curves for valves with detent and various spool types

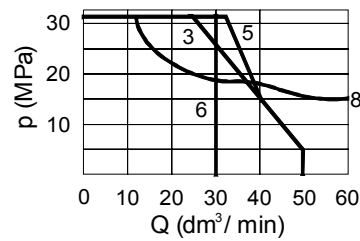
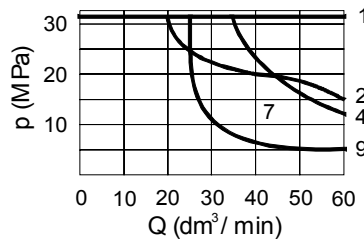

1	2	3	4	5	6	7	8	9
E1, M, H, C, D, Y	E, J, Q, L, U, W	A, B	G, T	F	V	P	R	T

**Note:**

The flow limits refer to typical application of 4-way directional control valve i.e. with using two lines e.g. P to A and B to T at the same time. In case of using 4-way directional control valve with one flow line e.g. P to A ( B plugged ) or A to T ( B plugged ) actual flow limits are considerably lower.

**SCHEMES**

Hydraulic scheme for directional control valve

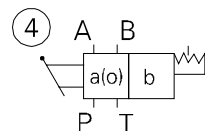
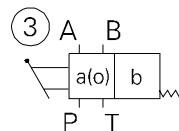
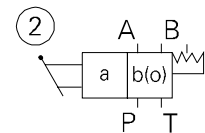
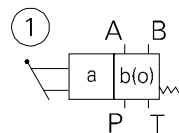

- item 1, 3 - two - position directional valve with return spring
- item 2, 4 - two - position directional valve with detent
- item 5 - three - position directional valve with return springs
- item 6 - three - position valve with detent

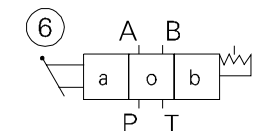
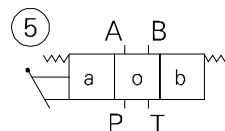

Spool schemes

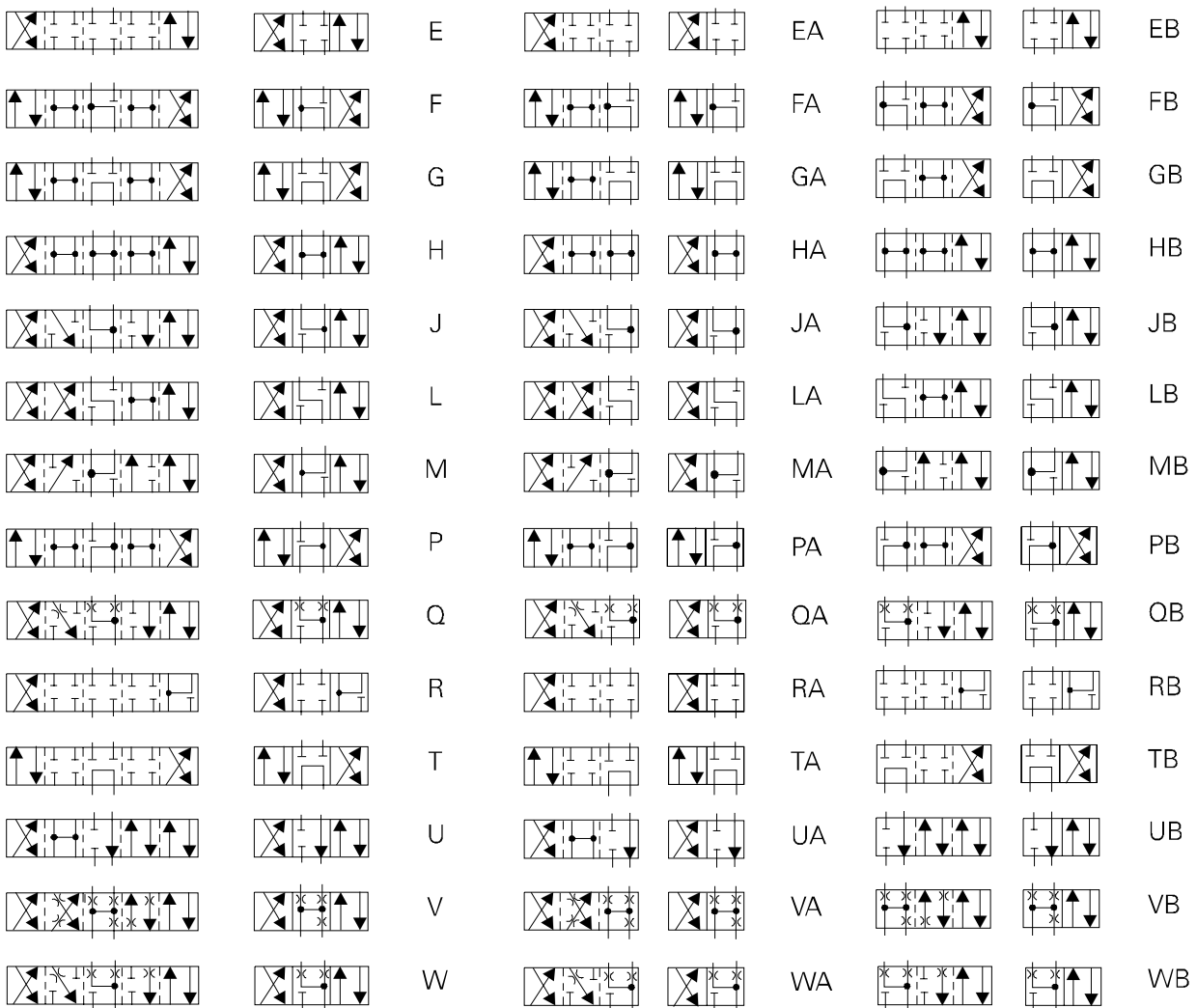
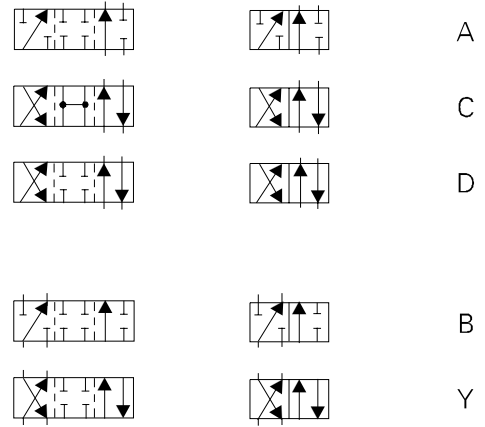

Note : Scheme E has version E1 with overlap positions as for spool P.  
 Spool type W makes section open in neutral position in approx. 3 % of nominal section.  
 Spool type W makes section open in neutral position in approx. 6 % of nominal section.

## HOW TO ORDER

Orders coded in the way showed below should be forwarded to the manufacturer.

	WMM 6			/			*
--	-------	--	--	---	--	--	---

<b>Number of service ports</b>	
3	= 3
4	= 4

<b>Control spool type</b> See schemes on page 5
--

<b>Series number:</b>	
50	= 50
( 50 - 59 ) - Installation and connection dimensions unchanged	

<b>Control spool positioning</b>	
Spring centering	= with no designation
With detent	= F

<b>Throttle insert</b>	
Without throttle insert	= with no designation
Throttle insert Ø 0.8	= B08
Throttle insert Ø 1.0	= B10
Throttle insert Ø 1.2	= B12

<b>Sealing</b>	
For fluids on mineral oil base	= with no designation
For fluids on phosphate ester base	= V

Additional requirements in clear text ( to be agreed with the manufacturer )
--

Coding example : 4 WMM6E1-50/B08

# MOUNTING DIMENSIONS FOR SUBPLATE

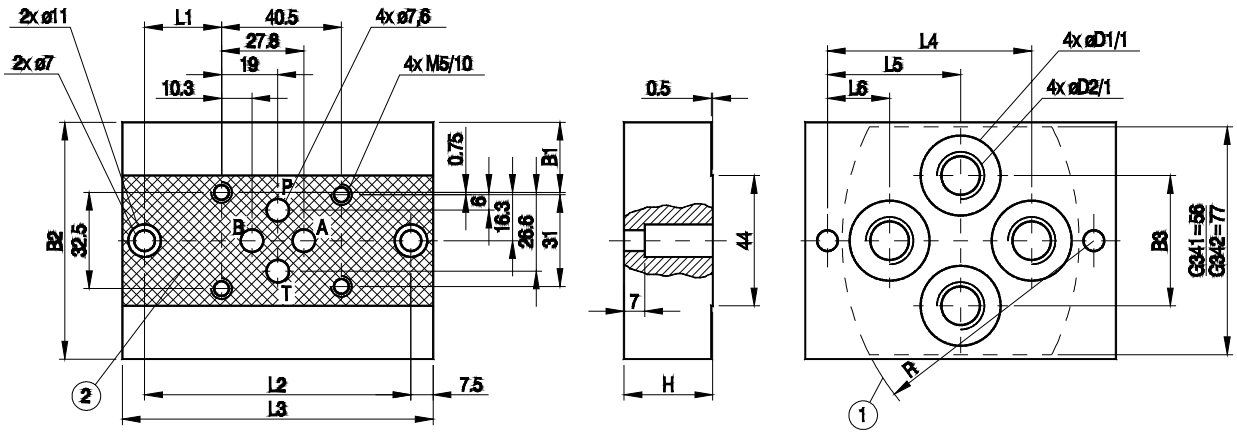

- 1 - Mounting face
- 2 - Recess in subplate face

Subplate weight - approx. 0.8 kg

Type	B1	B2	B3	L1	L2	L3	L4	L5	L6	H	D1	D2	R	T
G341/01	12.7	58	34	21	80	95	55	40	25	25	22	G1/4	70	13
G342/01	23.7	80	44	26	90	105	69	45	21	30	28	G3/8	85	13
G341/02	12.7	58	34	21	80	95	55	40	25	25	22	M14×1.5	70	15
G342/02	23.7	80	44	26	90	105	69	45	21	30	27	M16×1.5	85	16

Bolts mounting valve to subplate	Torque
4 × M5 × 50 -10.9 per PN-74/M-82302 (DIN 912)	9 Nm

Note : Subplate and mounting bolts must be ordered separately

PONAR WADOWICE S.A.  
ul. Wojska Polskiego 29  
34-100 Wadowice  
tel. 033/ 823 39 43, 823 30 41  
fax 033/ 873 48 80  
e-mail: ponar@ponar-wadowice.pl

